

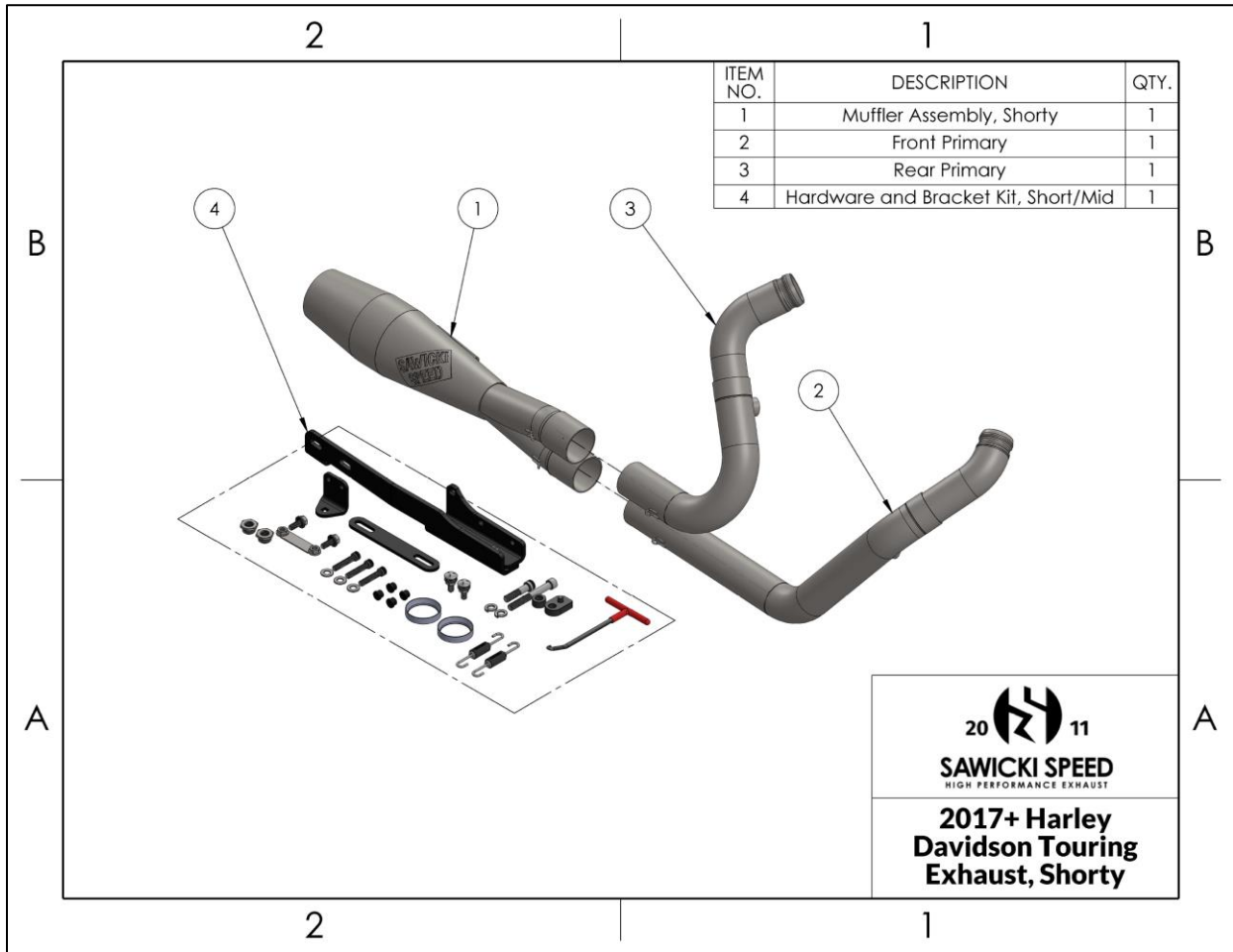

SAWICKI SPEED
HIGH PERFORMANCE EXHAUST

Harley Davidson Touring Short and Mid-Length Exhaust Installation Instructions

Fitment Table		
<u>Make/Model:</u>	<u>Model Year Range:</u>	<u>Factory Engine Option:</u>
Harley Davidson Touring, All	2017-2025+	107, 114, 117, 121, 135





SAWICKI SPEED

HIGH PERFORMANCE EXHAUST

ITEM NO.	DESCRIPTION	QTY.
1	Muffler Assembly, Mid-Length	1
2	Front Primary	1
3	Rear Primary	1
4	Hardware and Bracket Kit, Short/Mid	1

2011
SAWICKI SPEED
HIGH PERFORMANCE EXHAUST
2017+ Harley Davidson Touring Exhaust, Mid-Length



SAWICKI SPEED
HIGH PERFORMANCE EXHAUST

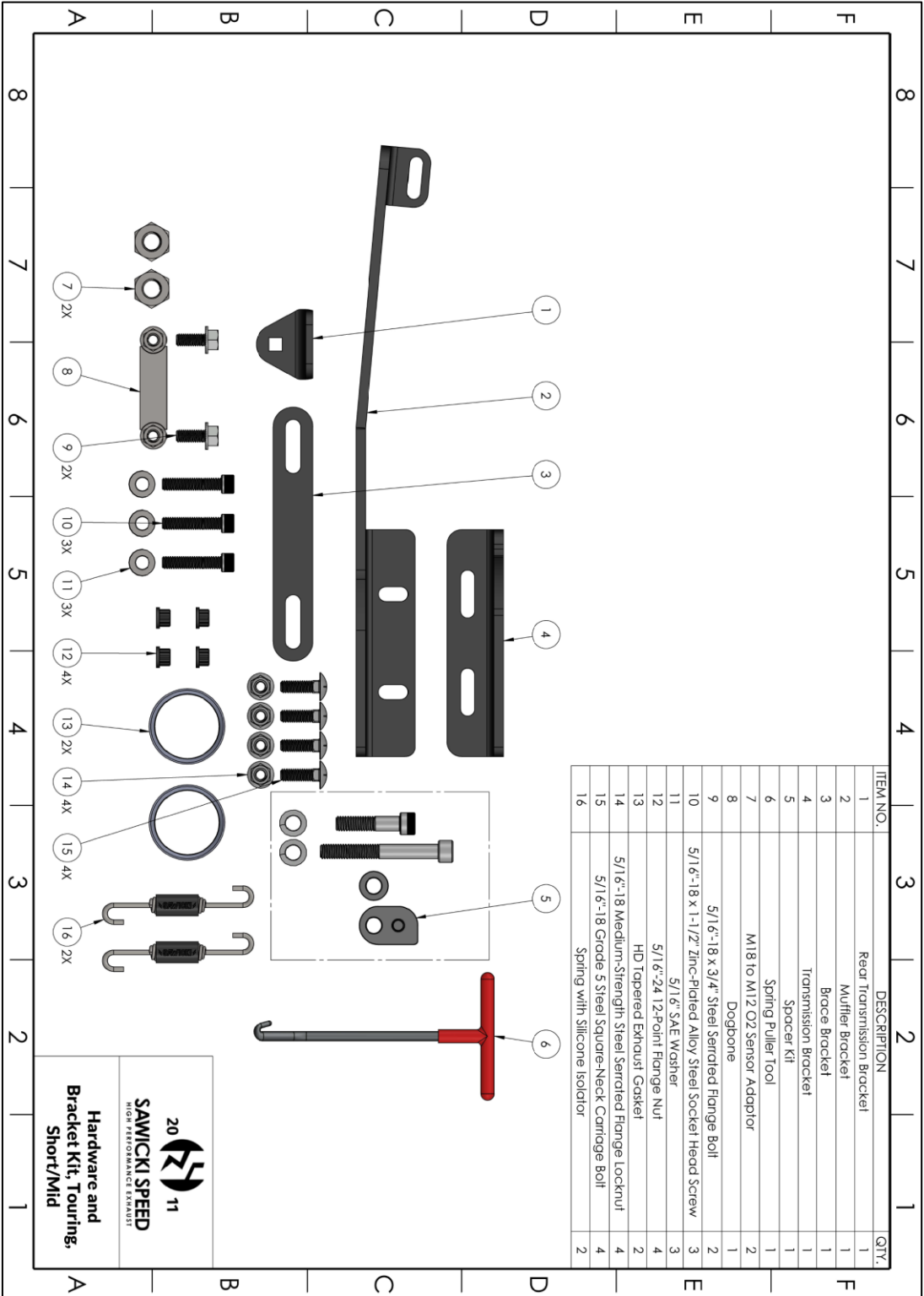

ITEM NO.	DESCRIPTION	QTY.
1	Rear Transmission Bracket	1
2	Muffler Bracket	1
3	Brace Bracket	1
4	Transmission Bracket	1
5	Spacer Kit	1
6	Spring Puller Tool	1
7	M18 to M12 O2 Sensor Adaptor	2
8	Dogbone	1
9	5/16"-18 x 3/4" Steel Serrated Flange Bolt	2
10	5/16"-18 x 1-1/2" Zinc-Plated Alloy Steel Socket Head Screw	3
11	5/16" SAE Washer	3
12	5/16"-24 12-Point Flange Nut	4
13	HD Tapered Exhaust Gasket	2
14	5/16"-18 Medium-Strength Steel Serrated Flange Locknut	4
15	5/16"-18 Grade 5 Steel Square-Neck Carriage Bolt	4
16	Spring with Silicone Isolator	2

20 11
SAWICKI SPEED
HIGH PERFORMANCE EXHAUST
Hardware and
Bracket Kit, Touring,
Short/Mid

Recommended Tool List:

-
- 1/2" Wrench
 - 7/8" Wrench
 - 11/16" or 17mm Wrench
 - 1/4" Drive Ratchet
 - Long 1/4" Drive Extension
 - 1/4" Drive Swivel
 - 3/8" Drive Ratchet
 - 3/8" Drive Extension
 - Flat Blade Screwdriver
 - 3/16" Allen Wrench/Socket
 - 5/16" Allen Wrench/Socket
 - 5/16" Socket, 1/4" Drive
 - 3/8" Socket, 1/4" Drive, **12-point**
 - 1/2" Socket, 1/4" Drive
 - 14mm Socket, 3/8" Drive
 - 15mm Socket, 3/8" Drive
 - 1/4" Allen Wrench/Socket
 - Snap-Ring Pliers

Step 1. Remove Stock Exhaust System

1. Start by removing both left and right-hand saddlebags. Set in a safe location on a soft surface to avoid scratching paint.
2. Remove the RH floorboard assembly by removing the two circled socket head cap screws using a 5/16" Allen wrench or socket.

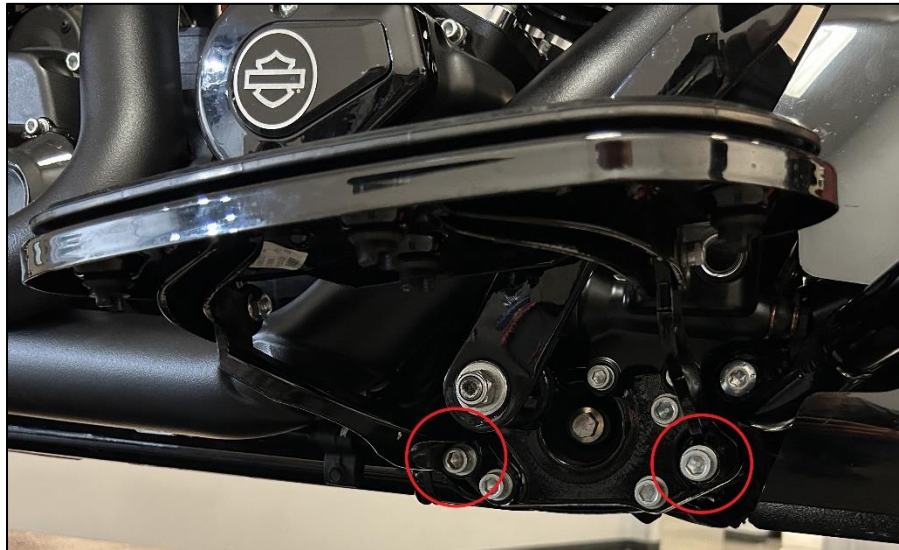

3. With the floorboard removed, remove the exhaust heat shields on the RH side of the bike. Each heat shield has two hose clamps that must be fully loosened, roughly located as shown in the next image.

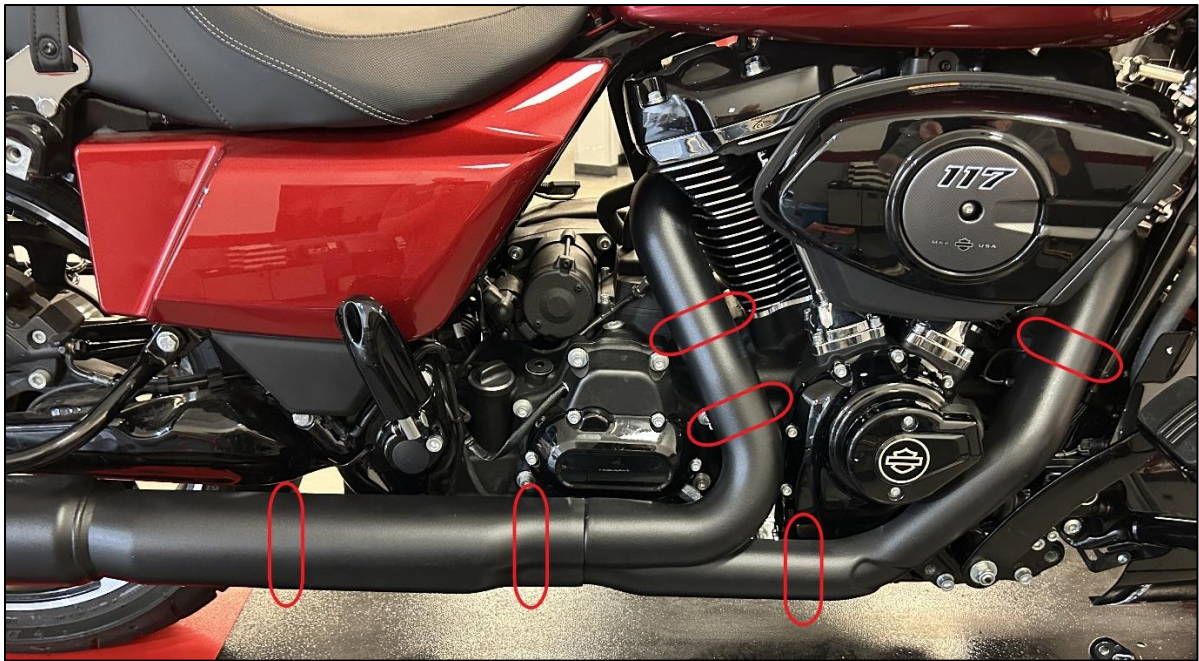

4. Next, remove the left and right-hand side mufflers. Loosen the clamps between the mufflers and the head pipes using a 15mm socket for the RH muffler clamp, and a 14mm socket for the LH muffler clamp. Remove the two muffler mounting bolts on both sides using a 1/2" socket.
5. Remove the rubber isolators and mount brackets from both sides. These can be removed by pushing the isolators towards the front of the bike.

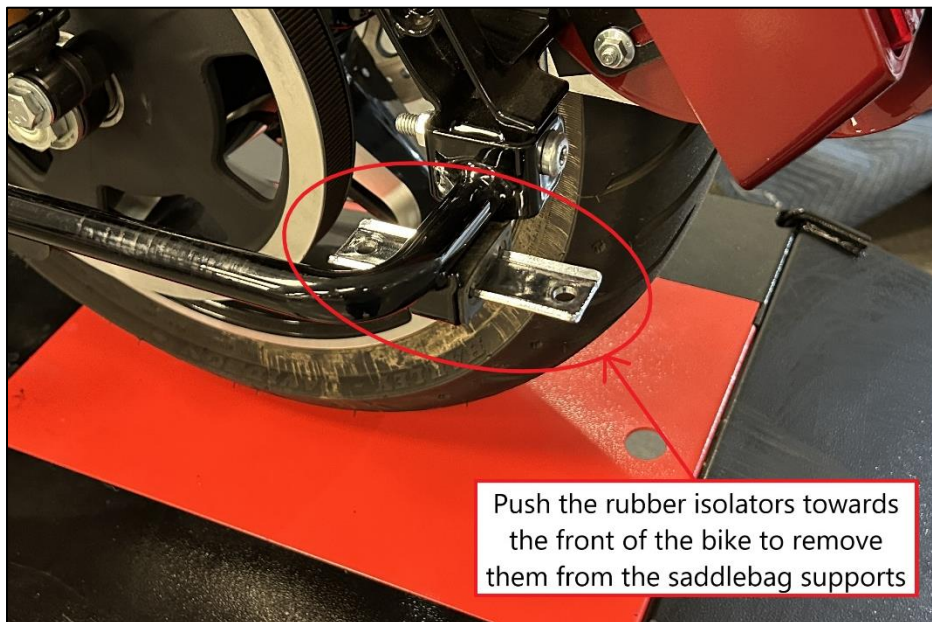

6. Remove the nut for the front primary mounting bracket near the cam cover, and the bolt for the rear crossover pipe mounting bracket using a 1/2" socket.

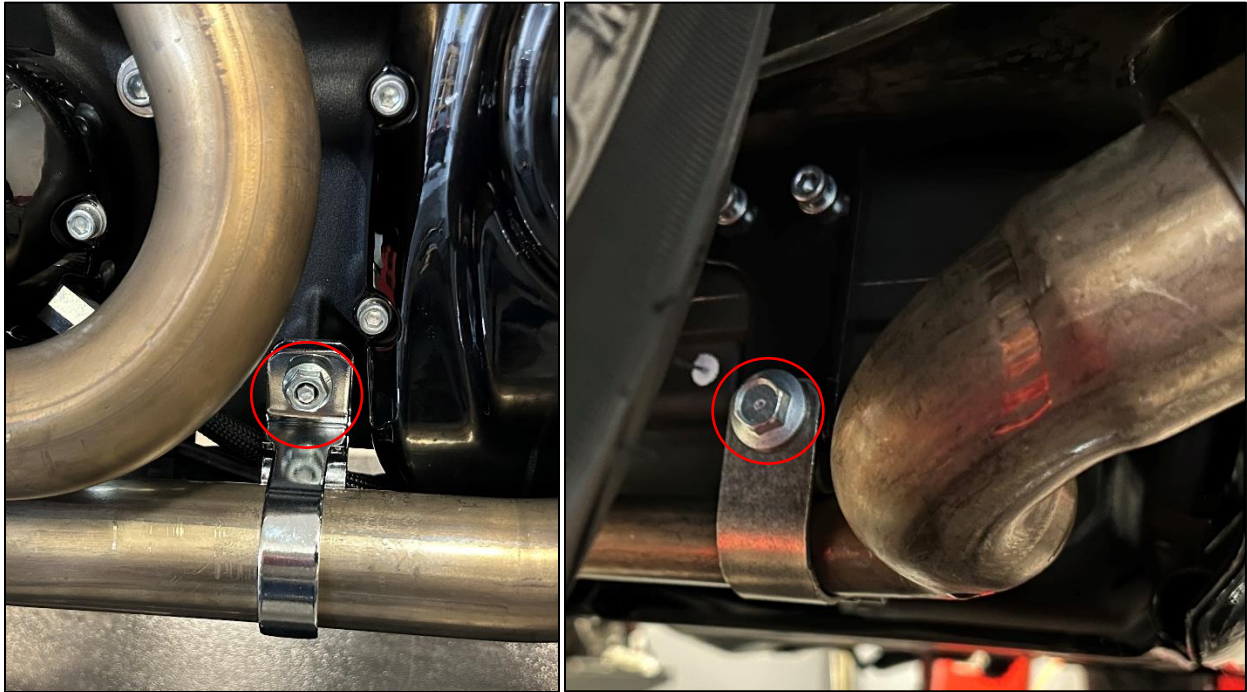

7. Loosen the crossover pipe clamp using a 15mm socket and remove the crossover pipe from the bike.
8. Remove the four exhaust flange nuts from the front and rear primary exhaust flanges using a 1/2" socket. **A long extension and swivel may be required for access.**
9. With the head pipe assembly loose, remove the factory O2 sensors using an 11/16" or 17mm wrench. The sensors and associated wiring can be removed completely by unplugging them from behind the RH side pod if desired.
10. The head pipe assembly should now be free to remove from the bike. Rotate the assembly away from the rear exhaust port first, then the front, being careful to avoid damaging paint.
11. Remove the C-clips and Exhaust Flanges from the factory head pipe, as they will be re-used for installation.

Step 2. Install Muffler Brackets

1. Remove the bottom three transmission cover bolts circled below. These bolts will not be re-used for installation.

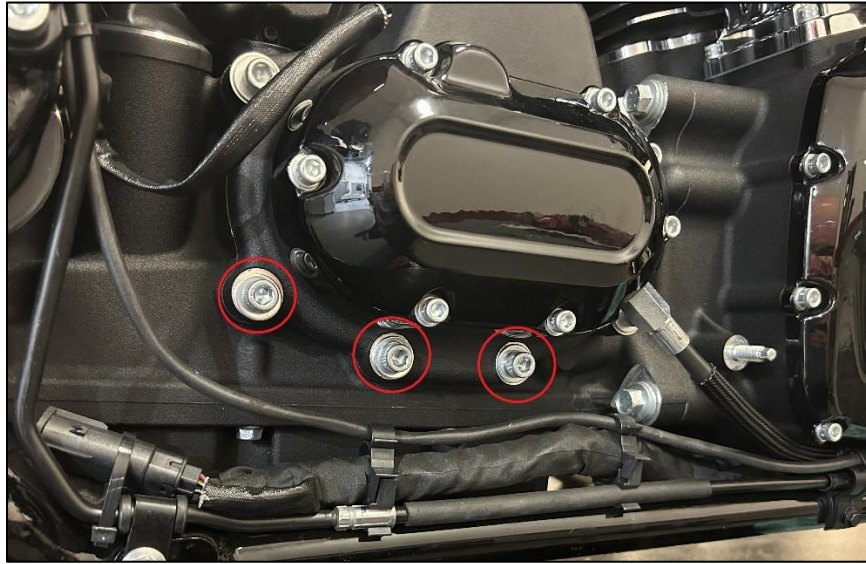

NOTE: For bikes with hydraulic clutches, the side cover may need to be removed for clearance to install the bracket. The side cover can be removed by using a 3/16" Allen wrench or socket to remove the two screws circled below. The side cover can be reinstalled after installing the transmission bracket.

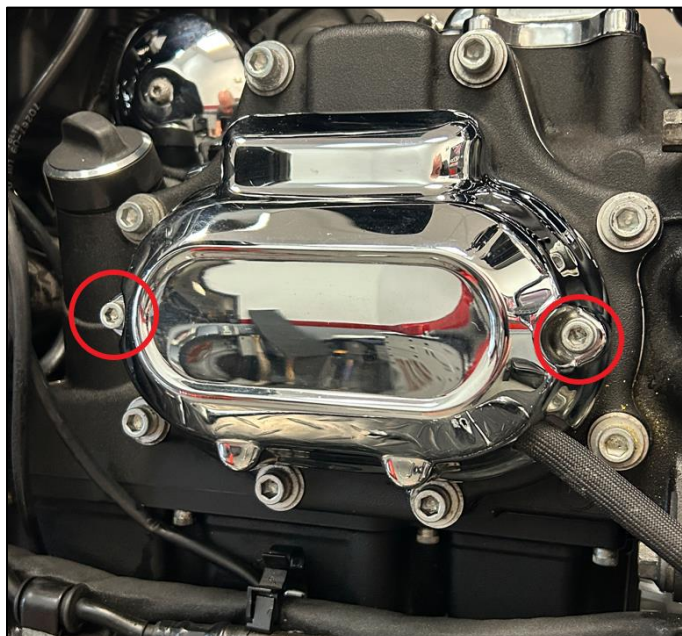



SAWICKI SPEED
HIGH PERFORMANCE EXHAUST

2. Install the transmission bracket as shown below using the three supplied 5/16"-18 x 1-1/2" long socket head cap screws and three of the supplied 5/16" washers. Torque the bolts to 22-25 ft-lbs beginning with the forward most bolt and work towards the rear. Install two of the supplied carriage bolts as shown.

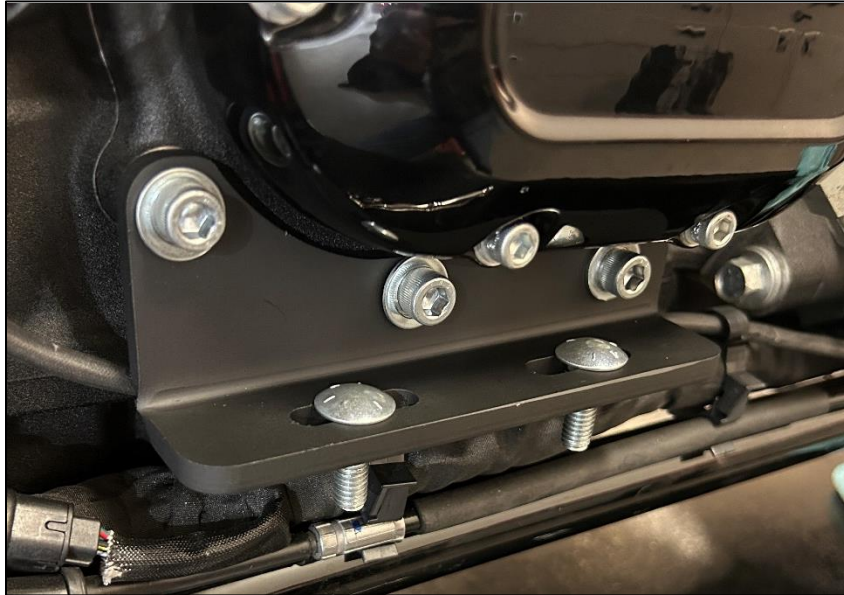

3. Remove the factory rear transmission mount bracket, using a 3/16" Allen wrench to remove the two cap screws. Install the provided rear transmission mount bracket using the factory cap screws as shown in the next image (these screws can be fully tightened). Install one of the supplied carriage bolts as shown.

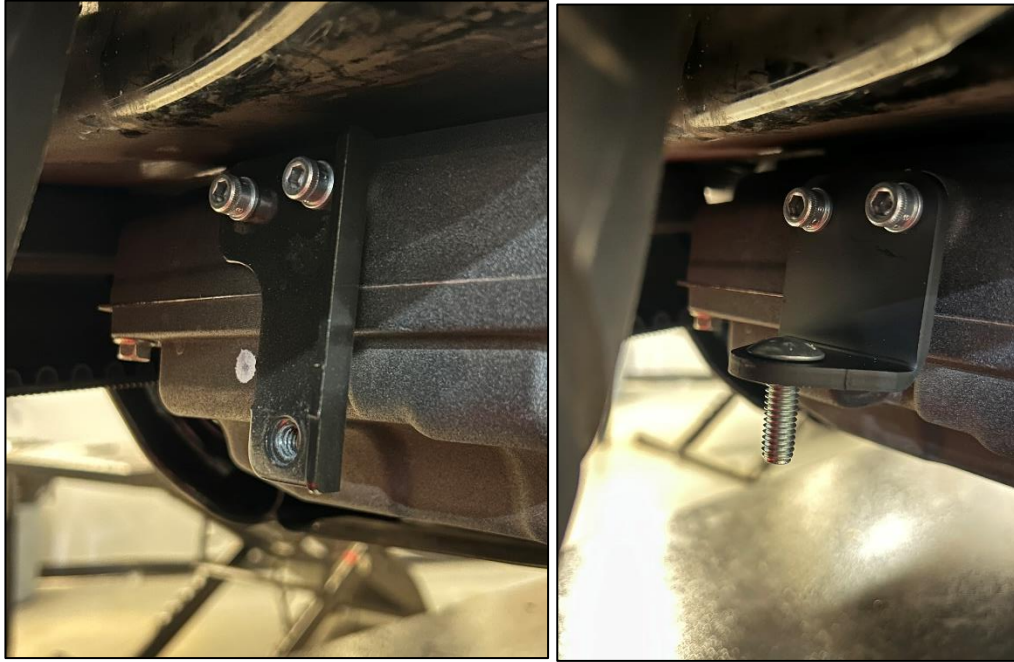

4. Install the muffler bracket to the bottom side of the transmission bracket as shown, using two of the supplied 5/16"-18 flange nuts to loosely secure the bracket – leave the nuts loose to allow full adjustability of the bracket.



5. Install the final carriage bolt into the rear horizontal slot on the muffler bracket and install the supplied brace bracket. Use the remaining two flange nuts supplied with the bracket kit to loosely secure the brace bracket to the rear transmission and muffler brackets – leave all hardware loose to allow for adjustment.

20  11

SAWICKI SPEED
HIGH PERFORMANCE EXHAUST

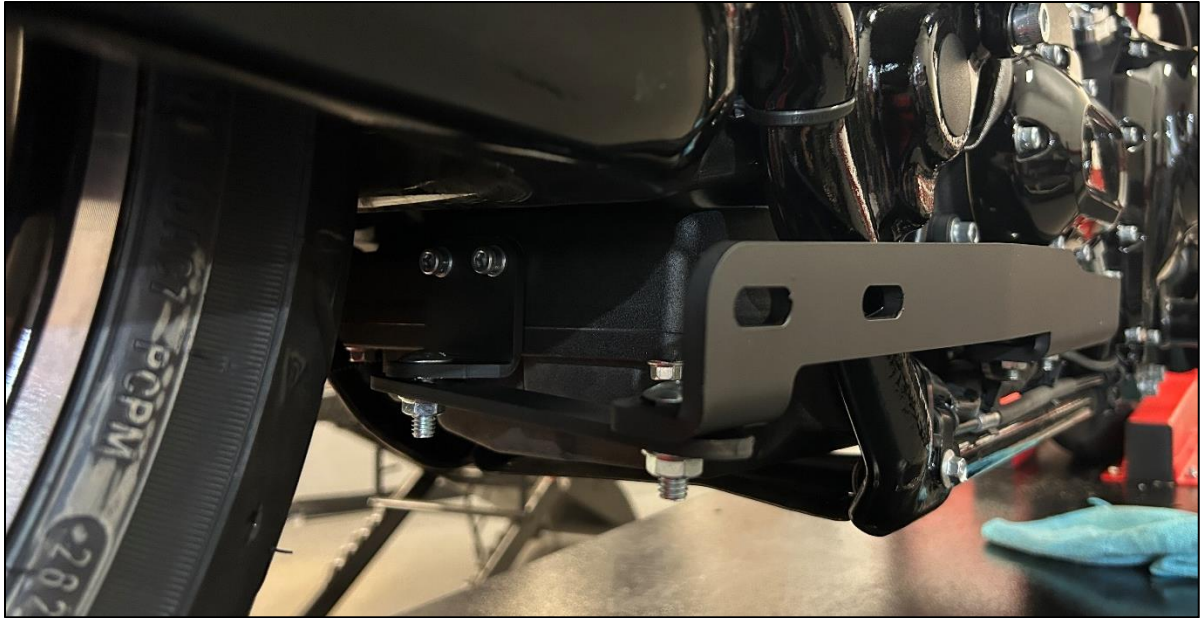

Step 3. Install Primaries

1. Begin by installing the supplied M12 to M18 O2 sensor adaptors into the O2 bungs on the new primaries (If using OE O2 sensors) using a 7/8" wrench or socket. Transfer the O2 sensors, exhaust flanges, and C-clips to the new primaries. If any of the factory c-clips, exhaust flanges, or exhaust studs are damaged or heavily corroded, replace them now. Be certain the O2 sensors from the front/rear OE primaries are transferred to the correct front/rear Sawicki primaries. Tighten the sensors using an 11/16" or 17mm wrench.



SAWICKI SPEED
HIGH PERFORMANCE EXHAUST

2. Remove the existing exhaust gaskets using a pick, screwdriver, or the supplied spring puller as a tool. **Be careful not to scratch or damage the cylinder head bore where the gasket seals.** Replace with the provided OE style tapered gaskets.
3. Loosely mount the front primary first by lining up the inlet with the exhaust port. Use a 12-point 3/8" socket to loosely tighten the provided 12-point ARP 5/16" -24 nuts to secure the primary to the cylinder head. It is recommended to use a long 1/4" drive extension and swivel to do this.
4. Loosely install the rear primary in the same manner as the front, leaving the exhaust flange nuts loose to allow the primaries to move freely.
5. With both primaries loosely installed, re-install the front and rear O2 sensors.

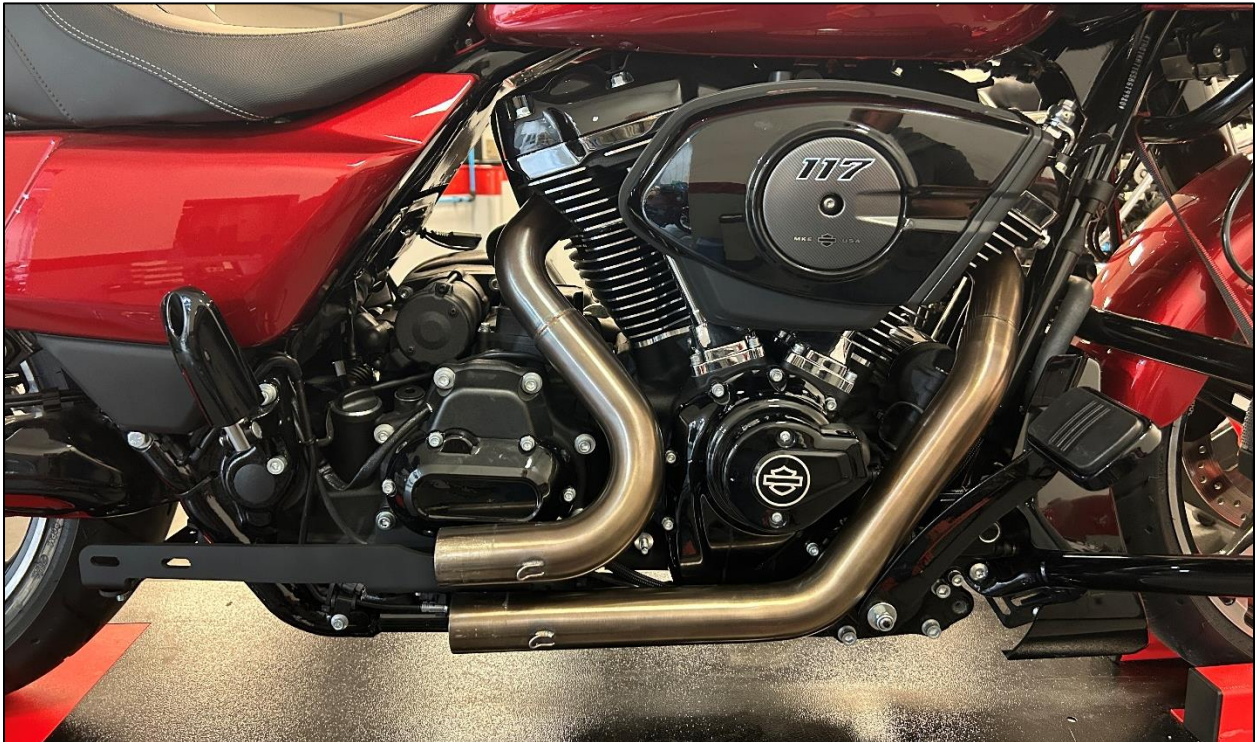

Step 4. Install and Mount Muffler

1. Install the muffler by slipping the merge over the front and rear primaries until both are fully seated. Some wiggling and rotating may be required to get the merge fully seated on the primaries.
2. Align the mounting bracket on the muffler with the long slot on the muffler bracket and insert the Dogbone into the mounting bracket on the muffler, with the serrated side of the nuts facing the bike. Use the two provided 5/16"-18 x 3/4" flange bolts to secure the muffler assembly to the muffler bracket, but do not fully tighten yet.

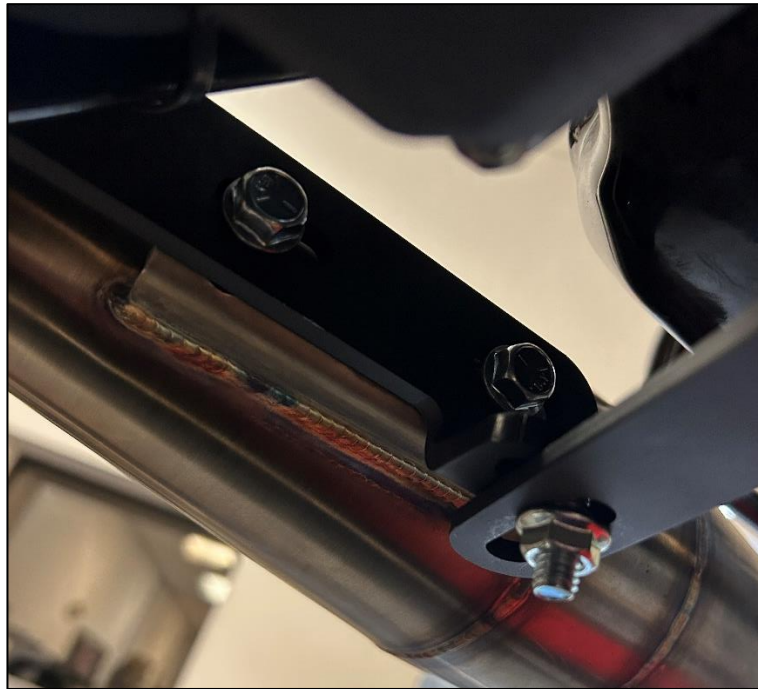

3. Install the provided springs to secure the muffler assembly to the primaries as shown below.

Note: It helps to have the bike in gear and the front or rear brake depressed to keep the bike from moving when installing the springs.



Step 5. Final Tightening and Leakage Checks

With all exhaust components loosely mounted, refer to the recommended tightening procedure below to ensure no binding occurs.

Note that with the tapered billet inlets, the pipes will tend to sag before being fully tightened. The nuts need to be tightened in equal amounts to “steer” the pipes into the correct location once fully tightened, especially the front primary.

1. Hand tighten all four exhaust flange nuts using a 3/8" 12-point socket in equal amounts to approximately 5 ft-lbs.
2. Torque rear cylinder upper nut to 10 ft-lb
3. Torque front cylinder upper nut to 10 ft-lb
4. Torque rear cylinder lower nut to 10 ft-lb
5. Torque front cylinder lower nut to 10 ft-lb
6. Tighten 5/16"-18 flange bolts using a 1/2" wrench from the muffler bracket to muffler, adjusting the muffler bracket to the desired location
7. Tighten the four remaining 5/16"-18 flange nuts for the bracket assembly using a 1/2" socket, starting with the nuts underneath the transmission bracket, then the nuts underneath the brace bracket

Install the RH floorboard assembly using the provided floorboard spacers and hardware shown below.

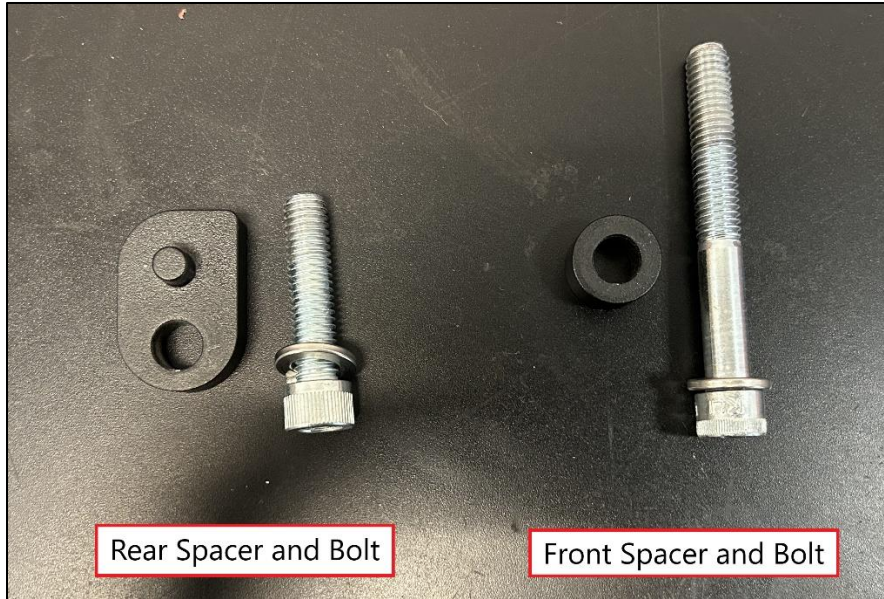

With the supplied spacers installed and the primary hardware properly tightened, there should be roughly a $7/16''$ to $1/2''$ between the cam cover and front primary, and floorboard bracket and front primary. If needed, loosen the exhaust flange bolts and re-tighten to adjust as necessary.

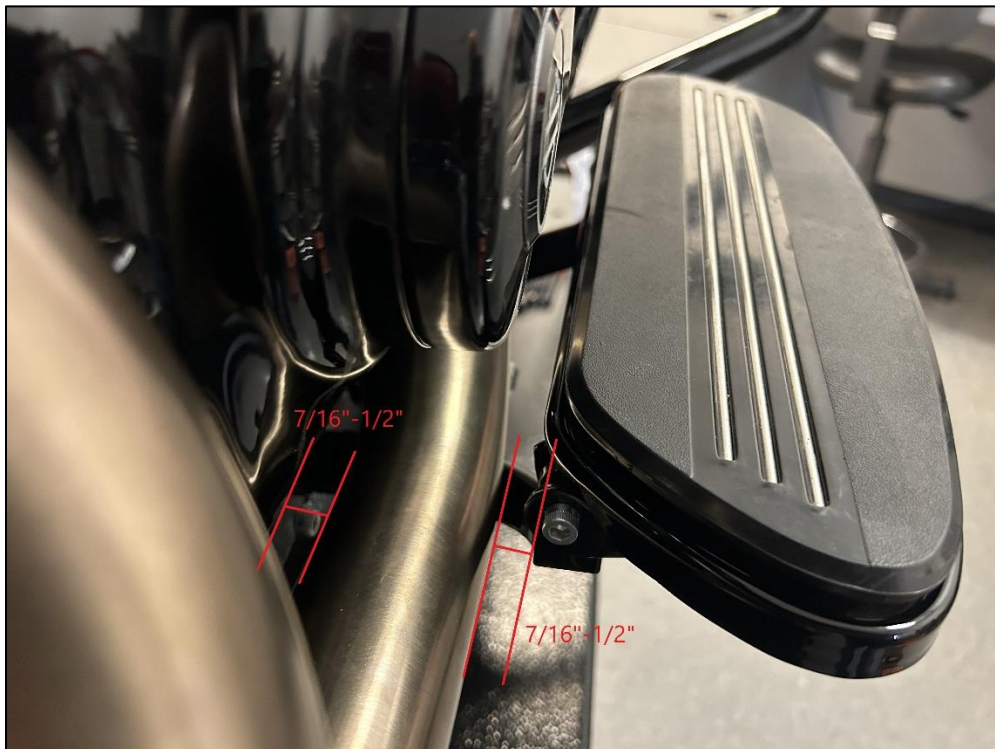



Finally, re-install the saddlebags to complete the installation.



Once everything is fully tightened, wipe the exhaust down with rubbing alcohol or brake cleaner to remove any oils or residue. Then start up the bike and check for leaks at the cylinder head gasket and O2 sensors, be very careful as the exhaust will get hot quickly. Should any leakage occur, snug up the associated hardware and re-check.

Note: For systems with billet endcaps, check that the three 1/4-20 bolts retaining the endcap are tight after a few heat cycles.